

L-SERIES
315SL BACKHOE



JOHN DEERE



**LIFT MORE
AND MULTITASK**



THE L-SERIES

*LOOKING FOR MORE
RELIABILITY AND PRODUCTIVITY?*

***WE'VE GOT
YOUR BACK.***



RELIABLE

PRODUCTIVE



GET MORE DONE WITH ONE

MULTIFUNCTION VERSATILITY, UNRIVALED CAPABILITY.

Why run two machines when one will do? Whether you're loading trucks, busting up blacktop, placing pipe, digging trenches, or moving materials, an L-Series Backhoe is more than up to the task. Improve your productivity on the jobsite with time-saving rear couplers for quick switching between attachments or do more with a multipurpose four-in-one loader bucket. The result: our most versatile backhoes ever.

Set it and go to work

When enabled on the sealed-switch control module, AutoShift automatically shifts the PowerShift transmission to the appropriate gear. Simply set the control lever to the highest gear desired, and the transmission will optimally shift based on engine rpm and ground speed.

True four-wheel drive on command

Limited-slip differential combined with mechanical-front-wheel drive (MFWD) provides true 4x4 performance and excellent traction in any ground conditions by delivering up to 65 percent of the available power to the wheel with the best traction.

Powerful engines

Trust John Deere PowerTech 4.5L engines to provide high power and torque rise that are proven, integrated, simple, and supported, for the muscle needed to power through any workday.

Your bucket list

Our multipurpose buckets have been enhanced to boost durability. New clamshell design features tilt-free dumping, a reinforced third cutting edge, and improved hinge profile for minimized material spillage compared to previous offerings.

Smooth gear changes

PowerShift transmission provides on-the-go clutchless gear changes for the operator.

Control the ride and the load

With optional ride control activated, front loader hydraulic cylinders act as a shock absorber, smoothing travel over rough terrain, helping full loads reach their destination, and reducing operator fatigue.



4WD
OPTION AT YOUR
COMMAND



BOOST OPERATOR PRODUCTIVITY. **WORKING IT OUT**

Through our Customer Advocate Group (CAG), owners and operators like you told us what you really wanted in a backhoe loader. And your best ideas helped us come up with some pretty great L-Series Backhoe features. When it comes to delivering what you need, nobody responds like John Deere.



< 6-SEC.

SIDE-TO-SIDE SHIFT
WITH POWERED SIDESHIFT OPTION



Make the shift

New powered sideshift option for the 315SL enables smooth side-to-side shifts in under six seconds, for more precise backhoe repositioning. Its design includes a series of two hydraulic cylinders used to shift the backhoe, eliminating the need for a chain-drive or pulley system. It's easily unlocked and controlled via the combination in-cab switch on the main control panel.

Powered sideshift option allows operators to take full advantage of the 315SL's narrow footprint with vertical stabilizers. This is particularly valuable in applications such as street repair; underground utility work in congested urban areas; constructing square trench boxes; and digging next to buildings, walls, or other structures.



Say goodbye to bumps in the road

Beat operator fatigue and work faster across large jobsites with an L-Series Backhoe's optional ride control and PowerShift transmission with AutoShift mode in base. These features enable you to effortlessly traverse any terrain and reduce spillage from loaded buckets in the roughest of conditions.

INNOVATIVE FEATURE

Spring into action

Spring-type rear coupler is designed to increase productivity and uptime. Operators need to leave the cab only once to switch attachments. And the handy control rod provided with the coupler is conveniently sized to fit in the standard toolbox, getting operators back to work faster and more effortlessly than with traditional manual couplers.



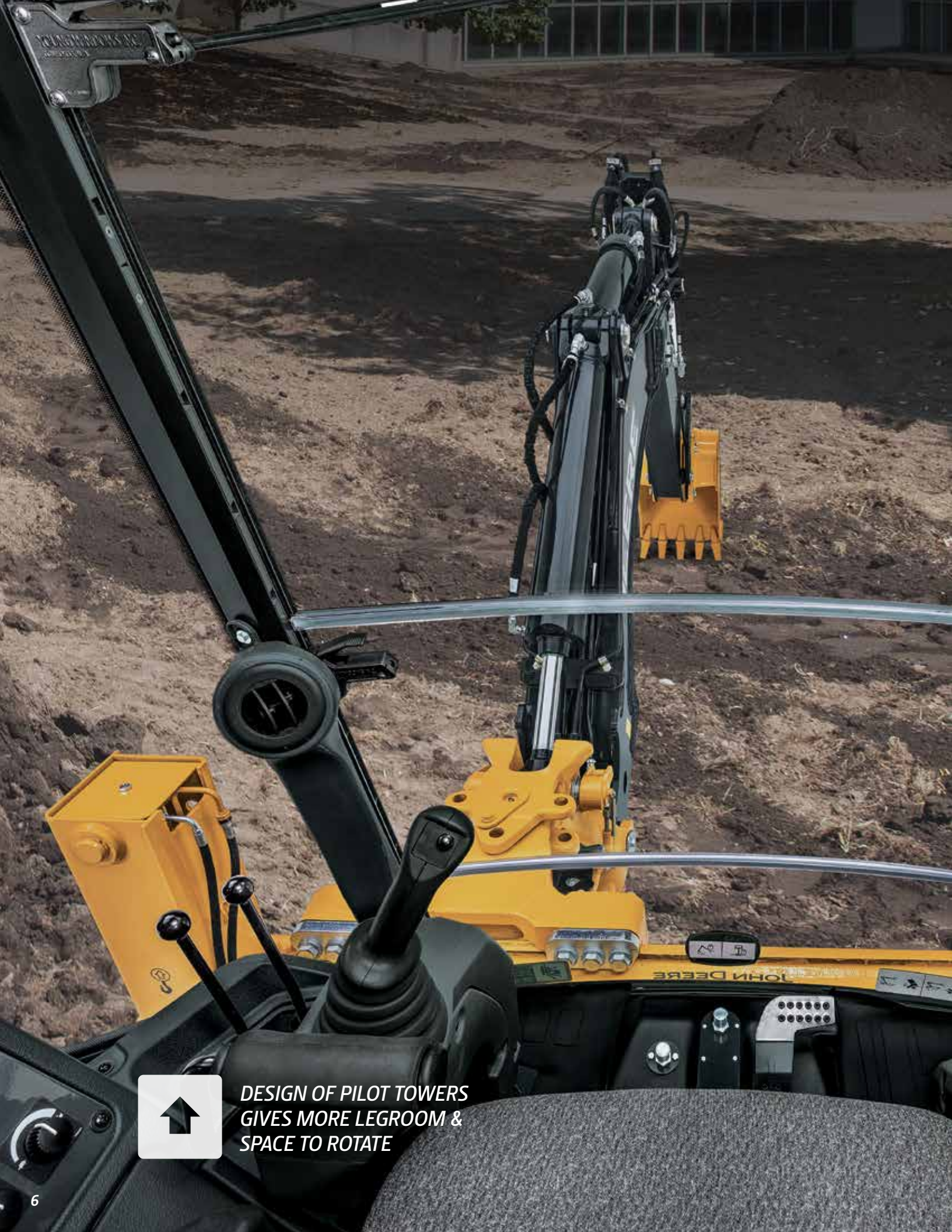

*DESIGN OF PILOT TOWERS
GIVES MORE LEGROOM &
SPACE TO ROTATE*



LED SPOT- & FLOODLIGHTS

Easy-to-use loader-control grip

“Palm-on-top” loader-control grip is even more comfortable and easy to use. Control of clutch disconnect, transmission quick-shift, auxiliary proportional roller, and momentary mechanical-front-wheel drive is at your fingertips.

Fatigue-beating comfort

L-Series Backhoes are loaded with creature comforts, including an efficient HVAC system and an adjustable mechanical or air-suspension seat.

Steering column controls

Exterior lights, wipers, and turn signals are conveniently located on the multifunction lever on the steering column — just like a regular vehicle — helping operators keep their eyes on the job at hand.

Extend your workday

LED lighting kit includes two spot- and eight floodlights, for enhanced visibility when your workday goes long.

UNSURPASSED RELIABILITY

WON'T BACK DOWN. OR LET YOU DOWN.

The 3155L Backhoe Loader is the latest addition to the lineup of John Deere Construction products manufactured at the TEDA factory. It maintains current Dubuque, Iowa, U.S.A. product design and quality levels — and now it's built in Tianjin, China.



Onboard diagnostics center

The most advanced onboard-diagnostics technology in the industry is standard on all L-Series Backhoes. The John Deere Precision Construction suite of telematic solutions includes JDLink Ultimate with real-time machine monitoring and remote diagnostics to help increase uptime while lowering operating costs.

Quick, clean filter changes

Vertical spin-on engine, transmission, and hydraulic filters and quick-release fuel filters allow fast, clean changes. Standard heavy-duty transmission oil filter increases reliability.

Multiple tire options

Choose from a variety of factory-installed tire options, for the traction, exceptional performance, and long service life your specific application requires.

Protect your investment

Machine-security system with touchpad passcode helps prevent unauthorized operation.

Diff-lock protection

Enabled through the monitor, differential-lock protection prevents engagement at high travel speeds and the resulting wear and tear on axle components.

Maintenance-free batteries

Standard maintenance-free batteries reduce periodic servicing, improve cold-starting reliability, and lengthen battery life.

Premium hydraulic oil

L-Series Backhoes come factory-filled with Hy-Gard 46 Plus premium all-season, anti-wear hydraulic oil specifically designed for construction equipment. Or for cold weather, opt for Hydrau XR, which offers all-season protection from -40 to 40 degrees C.



5.39 m
MAXIMUM DIGGING
DEPTH (WITH DIPPER-
STICK EXTENDED)



315SL SPECIFICATIONS

While general information, pictures, and descriptions are provided, some illustrations and text may include product options and accessories NOT AVAILABLE in all regions, and in some countries products and accessories may require modifications or additions to ensure compliance with the local regulations of those countries.

Engine		315SL			
Manufacturer and Model	John Deere PowerTech 4.5L turbocharged	John Deere PowerTech E 4.5L turbocharged			
Non-Road Emission Standard	EU Stage II	EU Stage IIIA			
Displacement	4.5 L	4.5 L			
Gross Peak Power	73 kW (98 hp) at 2,000 rpm	75 kW (100 hp) at 1,990 rpm			
Net Peak Power (ISO 9249)	69 kW (93 hp) at 1,970 rpm	71 kW (95 hp) at 1,900 rpm			
Net Peak Torque (ISO 9249)	386 Nm at 1,300 rpm	395 Nm at 1,500 rpm			
Net Torque Rise	46%	44%			
Lubrication	Pressure system with spin-on filter and cooler	Pressure system with spin-on filter and cooler			
Air Cleaner	Dual-stage dry type with safety element and evacuator valve	Dual-stage dry type with safety element and evacuator valve			
Cooling					
Fan Type	Suction-type, belt-driven cooling fan standard				
Engine Coolant Rating	-40 deg. C				
Engine Oil Cooler	Oil to water				
Powertrain					
Transmission	5-speed, helical-cut gears, full PowerShift transmission with hydraulic reverser standard; electric clutch cutoff on loader lever; AutoShift transmission standard				
Torque Converter	Single stage, dual phase with 2.63:1 stall ratio, 280 mm	Single stage, dual phase with 2.63:1 stall ratio, 280 mm			
Maximum Travel Speeds Measured With 16.9-28					
Rear Tires	<i>Forward</i>	<i>Reverse</i>	<i>Forward</i>	<i>Reverse</i>	
Gear 1	5.8 km/h	7.3 km/h	5.7 km/h	7.3 km/h	
Gear 2	10.7 km/h	13.5 km/h	10.6 km/h	13.4 km/h	
Gear 3	22.0 km/h	21.7 km/h	21.8 km/h	21.5 km/h	
Gear 4	40.0 km/h	—	39.7 km/h	—	
Gear 5	40.0 km/h	—	40.0 km/h	—	
Axles					
Axle Oscillation, Stop to Stop, Front Axle	22 deg.		22 deg.		
Axle Ratings	<i>Front</i>	<i>Rear</i>	<i>Front</i>	<i>Rear</i>	
SAE J43	5500 kg	7500 kg	5500 kg	7500 kg	
Dynamic	9000 kg	10 000 kg	9000 kg	10 000 kg	
Static	26 000 kg	26 500 kg	26 000 kg	26 500 kg	
Ultimate	42 500 kg	42 500 kg	42 500 kg	42 500 kg	
Differentials					
Mechanical-Front-Wheel-Drive (MFWD) Axle	Limited-slip traction control		Limited-slip traction control		
Rear Axle	Foot actuated, hydraulically engaged 100% mechanical lock		Foot actuated, hydraulically engaged 100% mechanical lock		
Steering (ISO 5010)					
Axle	<i>MFWD</i>	<i>Non-Powered Front</i>	<i>MFWD</i>	<i>Non-Powered Front</i>	
Curb-Turning Radius					
With Brakes	3.53 m	3.45 m	3.53 m	3.45 m	
Without Brakes	4.02 m	3.90 m	4.02 m	3.90 m	
Bucket-Clearance Circle					
With Brakes	10.10 m	10.04 m	10.10 m	10.04 m	
Without Brakes	10.84 m	10.70 m	10.84 m	10.70 m	
Steering Wheel Turns (lock to lock)	3.6	4.3	3.6	4.3	
MFWD Axle	Heavy duty, outboard planetary final drives distribute shock loads over 3 gears				
Rear Axle	Heavy duty, outboard planetary final drives distribute shock loads over 4 gears				
Brakes (ISO 3450)					
Service	Power assisted, hydraulic wet disc, mounted inboard, self-adjusting and self-equalizing				
Parking	Spring applied, hydraulically released, wet, multi-disc, independent of service brakes with electric switch control				

315SL SPECIFICATIONS



While general information, pictures, and descriptions are provided, some illustrations and text may include product options and accessories NOT AVAILABLE in all regions, and in some countries products and accessories may require modifications or additions to ensure compliance with the local regulations of those countries.

Hydraulics		315SL	
Main Pump	Open-center system, tandem gear pump with unloader		
Pump Flow at 2,200 rpm			
Backhoe	136 L/m		
Loader	106 L/m		
System Relief Pressure, Backhoe and Loader	24 993 kPa		
Controls			
Backhoe	2-lever mechanical standard, pilot controls with pattern select and manual and/or electric auxiliary functions optional		
Loader	Single-lever control with electric clutch cutoff switch standard; manual auxiliary function (2nd lever), single-lever control with electric clutch cutoff switch, electrohydraulic (EH) proportional auxiliary roller, MWFD (momentary), and transmission quick-shift optional		
Electrical			
Voltage	12 volt		
Alternator Rating	145 amp		
Lights	10 halogen: 4 front, 4 rear, and 2 side docking (32,500 candlepower each); turn signals and flashers: 2 front and 2 rear; stop and taillights; and 2 rear reflectors; front drive lamps with 55/60-watt halogen, plate lamp, reverse lamp, and front marker lamps; factory-installed option for 2 LED spotlights and 8 LED floodlights in lieu of the standard halogen light package		
Operator Station			
Type (ISO 3471)	Fully enclosed cab, isolation mounted, ROPS/FOPS, left/right access, with molded roof; optional canopy		
Tires/Wheels			
	<i>Front</i>	<i>Rear</i>	
Non-Powered Front Axle	12.5/80-18 F3 (12)	16.9L-28 R4 (12)	
With MFWD	12.5/80-18 R4 (10)	16.9L-28 R4 (12)	
Serviceability			
Refill Capacities			
Cooling System			
Cab	27.5 L		
Canopy	25.7 L		
Rear Axle	18.0 L		
Engine Oil (including vertical spin-on filter)	13.0 L		
Torque Converter and Transmission	15.1 L		
Fuel Tank (with ground-level fueling)	128.7 L		
Hydraulic System	126.8 L		
Hydraulic Reservoir	45.0 L		
MFWD Housing			
Axle	6.5 L		
Planetary (each)	0.9 L		
Operating Weights			
With Full Fuel Tank, 79-kg Operator, and Standard Equipment	7854 kg		
Typical With Extendable Dipperstick and 204-kg Counterweight	8280 kg		
Optional Components (weight difference between base equipment and option)			
Cab	293 kg		
MFWD With Tires	220 kg		
Extendable Dipperstick	222 kg		
Front Loader Coupler	0 kg		
Backhoe Bucket Coupler	0 kg		
Powered Side-Shift	121 kg		

While general information, pictures, and descriptions are provided, some illustrations and text may include product options and accessories NOT AVAILABLE in all regions, and in some countries products and accessories may require modifications or additions to ensure compliance with the local regulations of those countries.

Overall Dimensions		315SL
A	Ground Clearance, Minimum	351 mm
B	Overall Length, Transport	5.96 m
C	Stabilizer Spread	2.26 m
D	Height to Top of ROPS/Cab	2.84 m
E	Length From Axle to Axle	
	Non-Powered Front Axle	2.16 m
	MFWD Axle	2.19 m

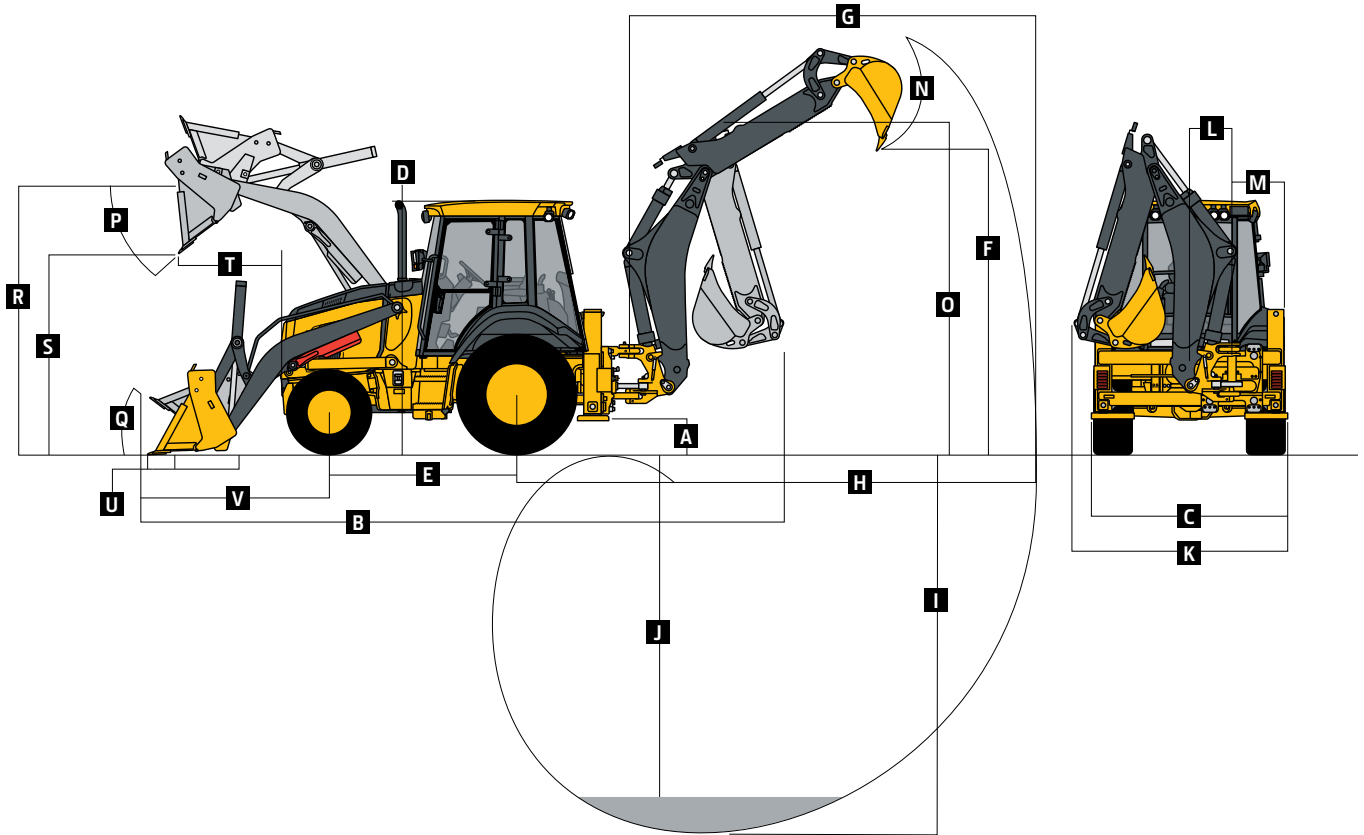

Backhoe Dimensions and Performance

Backhoe specifications are with 610-mm x 0.21-m³ bucket; dipper lift specs are with a boom angle of 65 deg.

Bucket Range	305–762 mm	
Digging Force		
Bucket Cylinder	55.0 kN	
With Heavy-Duty Cylinder Option	67.9 kN	
Crowd Cylinder	36.6 kN	
Swing Arc	180 deg.	
Operator Control	2 levers	

	With Optional Extendable Dipperstick		
	With Standard Backhoe	Retracted	Extended
F Loading Height, Truck Loading Position	3.65 m	3.77 m	4.39 m
G Reach From Center of Swing Pivot	5.44 m	5.61 m	6.62 m
H Reach From Center of Rear Axle	6.80 m	6.98 m	7.98 m
I Digging Depth (SAE maximum)	4.08 m	4.24 m	5.29 m

While general information, pictures, and descriptions are provided, some illustrations and text may include product options and accessories NOT AVAILABLE in all regions, and in some countries products and accessories may require modifications or additions to ensure compliance with the local regulations of those countries.

Backhoe Dimensions and Performance (continued) 315SL

Backhoe specifications are with 610-mm x 0.21-m³ bucket; dipper lift specs are with a boom angle of 65 deg.

	With Standard Backhoe	With Optional Extendable Dipperstick Retracted	Extended
J Digging Depth (SAE)			
610-mm Flat Bottom	4.03 m	4.20 m	5.26 m
2440-mm Flat Bottom	3.68 m	3.87 m	5.00 m
K Overall Width (less loader bucket)	2.43 m	2.41 m	—
L Side-Shift From Tractor Centerline	537 mm	537 mm	537 mm
M Wall to Swing Centerline	604 mm	604 mm	604 mm
N Bucket Rotation	190 deg.	190 deg.	190 deg.
O Transport Height	3.71 m	3.72 m	3.72 m

Loader Dimensions and Performance

P Bucket Dump Angle, Maximum	45 deg.	
Q Rollback Angle at Ground Level	40 deg.	
	<i>Heavy-duty</i>	<i>Multipurpose</i>
Bucket Capacity	1.00 m ³	1.00 m ³
Width	2337 mm	2337 mm
Weight	521 kg	863 kg
Breakout Force	47.2 kN	43.5 kN
Lift Capacity, Full Height	3277 kg	2792 kg
R Height to Bucket Hinge Pin, Maximum	3.45 m	3.45 m
S Dump Clearance, Bucket at 45 deg.	2.69 m	2.65 m
T Reach at Full Height, Bucket at 45 deg.	726 mm	768 mm
U Digging Depth Below Ground, Bucket Level	146 mm	142 mm
V Length From Front Axle Centerline to Bucket Cutting Edge	2.05 m	2.10 m

Lift Capacity With Bucket

Dipper-lift specs are with a boom angle of 65 deg. Lift capacities are over-end values in kg of the maximum lift force available.

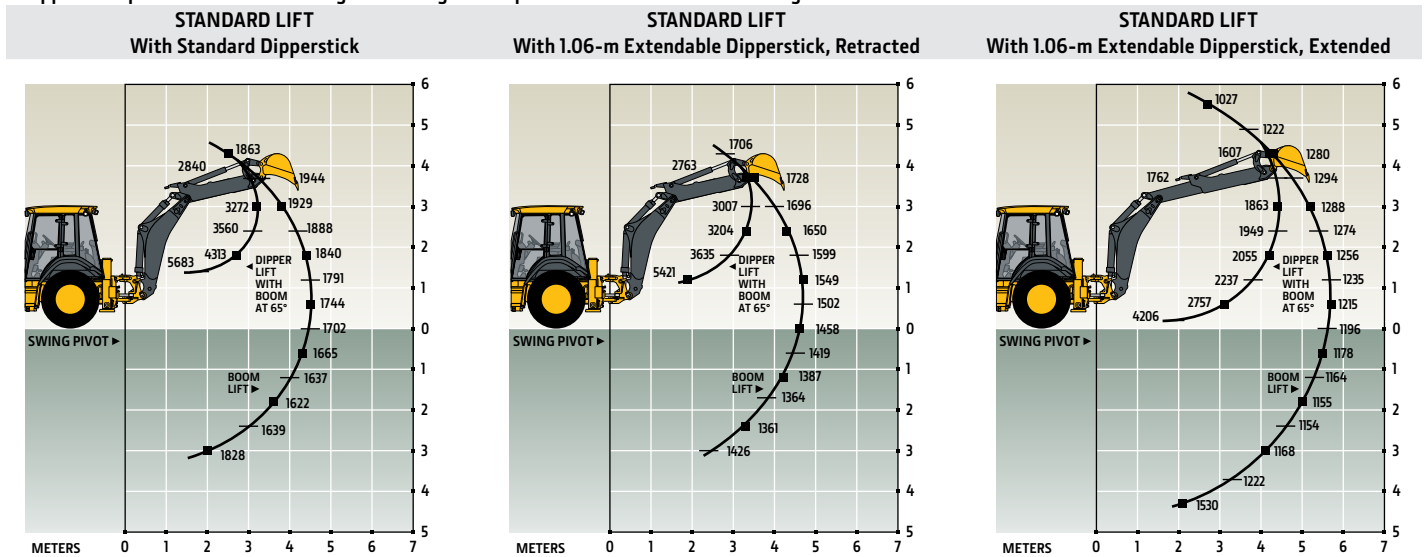

Lift capacities are over end with stabilizers down and tires tangent to ground.

Additional equipment

Key: ● Standard ▲ Optional or special See your John Deere dealer for further information.

315SL Engine

- Coolant recovery tank with low-level indicator
- Serpentine belt with automatic belt tensioner
- Suction-type, belt-drive cooling fan
- ▲ Chrome exhaust extension
- ▲ 1,000-watt electric engine coolant heater

Powertrain

- PowerShift transmission: Torque converter with twist-grip TCL and neutral safety switch interlock (1st through 5th gears)
- 5th-gear overdrive
- AutoShift transmission
- Transmission oil cooler
- ▲ Transmission remote oil-sampling port
- Differential lock, electric foot actuated
- Auto shutdown
- Planetary final drives
- Power-assisted hydraulic service brakes (conform to ISO 3450): Inboard, wet multi-disc, self-adjusting and self-equalizing
- Parking/emergency brake with electric switch control (conforms to ISO 3450): Spring applied, hydraulically released wet multi-disc / Independent of service brakes
- Hydrostatic power steering with emergency manual mode
- ▲ Non-powered front axle
- Mechanical-front-wheel drive (MFWD) with traction-control limited-slip differential: Electric on/off control / Sealed axle
- Automatic MFWD braking (4th and 5th gear over-drive only)
- ▲ MFWD driveshaft guard

315SL Backhoe

- Standard dipperstick, 4.08-m digging depth
- ▲ Extendable dipperstick, 1.06-m extension
- ▲ Heavy-duty backhoe bucket cylinder
- ▲ SAE (excavator) 2-lever mechanical backhoe controls
- ▲ 2-lever pilot controls with pattern-selection feature
- Backhoe transport lock lever
- Swing lock pin stored in operator's station
- Stabilizers with 2-direction anti-drift valves
- ▲ Severe-duty backhoe bucket with lift loops
- ▲ Auxiliary backhoe valve for swingers, thumbs, etc. with auxiliary plumbing
- ▲ Auxiliary backhoe valve for hammers and compactors with auxiliary plumbing
- ▲ Controlled load-lowering device and object-handling kit

Loader[†]

- Loader bucket anti-spill (rollback)
- Return-to-dig feature
- Single-lever control with electric clutch disconnect
- Bucket-level indicator
- Loader boom service lock
- ▲ Auxiliary loader hydraulics with 2-lever control
- ▲ Hydraulic coupler for buckets, forks, etc.
- ▲ Ride control
- ▲ Controlled load-lowering device kit

[†]See dealer for range of heavy-duty, multipurpose, and coupler buckets and forks.

Hydraulic System

- 136-L/m tandem-gear pump, open-center system
- Auto idle
- Dedicated hydraulic reservoir

While general information, pictures, and descriptions are provided, some illustrations and text may include product options and accessories NOT AVAILABLE in all regions, and in some countries products and accessories may require modifications or additions to ensure compliance with the local regulations of those countries.

Net engine power is with standard equipment including air cleaner, exhaust system, alternator, and cooling fan at test conditions specified per ISO 9249. No derating is required up to 3050-m altitude. Specifications and design subject to change without notice. Wherever applicable, specifications are in accordance with ISO standards. Except where otherwise noted, these specifications are based on a unit with 16.9-28 In. 12 PR (R4) tubeless rear and 12.5/80-18 12 PR (R4) front tires and 1.00-m³ loader bucket.

Additional equipment *(continued)*

Key: ● Standard ▲ Optional or special See your John Deere dealer for further information.

315SL Electrical System

- 12-volt system
- 145-amp alternator
- Single battery with 175-min. reserve capacity and 950 CCA
- ▲ Dual batteries with 350-min. reserve capacity and 1,900 CCA
- ▲ Remote jump posts and battery disconnect

Lights

- Halogen lights (10), 32,500 candlepower each (4 front driving/working, 4 rear working, and 2 side docking)
- Turn signal/flashing (2 front and 2 rear)
- Rear stop and tail (2)
- ▲ LED lights, 2 spot- and 8 floodlights

Operator's Station

- Modular-design ROPS/FOPS (Level 2) canopy with molded roof (meets ISO 3449 and ISO 3471/SAE J1040): Isolation mounted
- Molded floor mats (with pilot controls only)
- 12-volt outlet
- Lockable right-side storage
- ▲ Lockable left-hand storage with cup holders
- ▲ Interior front-view mirror
- ▲ Outside rearview mirrors
- Rotary-dial hand throttle
- Suspended foot throttle
- ▲ Air-suspension seat
- Tilt steering, infinitely adjustable
- Keyless start
- Machine security (enabled through monitor)
- Digital display of engine hours, engine rpm, and system voltage
- Sealed-switch module

315SL Operator's Station *(continued)*

- Multi-function lever: Turn signals / Windshield wipers / Some light functionality
- Monitor system with audible and visual warnings: Engine air restriction / Low alternator voltage / Engine oil pressure / Hydraulic filter restriction / Parking brake on/off / After-treatment temperature / Transmission fluid temperature / Fuel / Hour meter / Machine diagnostic information via 4-push-button/LCD operator interface
- **Cab with Dual Doors and A/C:** Mechanical-suspension deluxe fabric swivel seat with lumbar adjustment / Headliner, dome light, left and right cab doors, tinted safety glass, windshield wipers (1 rear and 1 front), front windshield washer, fresh-air intake, and heater/defroster/pressurizer (11.7-kW heater) / A/C (7.6-kW output and CFC-free R134a refrigerant)
- ▲ Premium radio package (includes additional 12-volt and USB outlets)

Overall Vehicle

- 1-piece unitized construction mainframe
- Vehicle tie-downs (2 front and 2 rear)
- Remote grease bank for front axle
- Heavy-duty front bumper
- ▲ Front counterweight, 204 kg
- ▲ Rubber grille bumpers
- Fuel tank, 128.7 L, ground-level fueling
- 2-position easy-tilt hood
- Extended grille frame
- Removable toolbox with padlock hasp
- Vandal protection for locking monitor, engine hood, toolbox, hydraulic reservoir, and fuel tank
- Reverse warning alarm
- Dent-resistant full-coverage rear fenders
- JDLink Ultimate wireless communication system (available in specific countries; see your dealer for details)

While general information, pictures, and descriptions are provided, some illustrations and text may include product options and accessories NOT AVAILABLE in all regions, and in some countries products and accessories may require modifications or additions to ensure compliance with the local regulations of those countries.

Net engine power is with standard equipment including air cleaner, exhaust system, alternator, and cooling fan at test conditions specified per ISO 9249. No derating is required up to 3050-m altitude. Specifications and design subject to change without notice. Wherever applicable, specifications are in accordance with ISO standards. Except where otherwise noted, these specifications are based on a unit with 16.9-28 1n. 12 PR (R4) tubeless rear and 12.5/80-18 12 PR (R4) front tires and 1.00-m³ loader bucket.



JOHN DEERE

JohnDeere.com

RISING TO THE CHALLENGE.

Every day brings new challenges — demanding jobsites, long hours, and an increasing focus on uptime. Our job is to bring you the opportunities to overcome them. Our experienced engineers, specialized service techs, and global parts and service network are always ready to step up to help you **Run Your World.**



DKA315SL (21-04)